

Variance for Gazebo

27 Jameson Hill Road
Clinton Corners, NY 12514

Owner/Applicants:
Theresa Weller & Steven Thrower



The proposed gazebo will provide a much needed shaded spot for relaxation. Its design and appearance will compliment the heritage of the existing 1840's farmhouse currently on the property

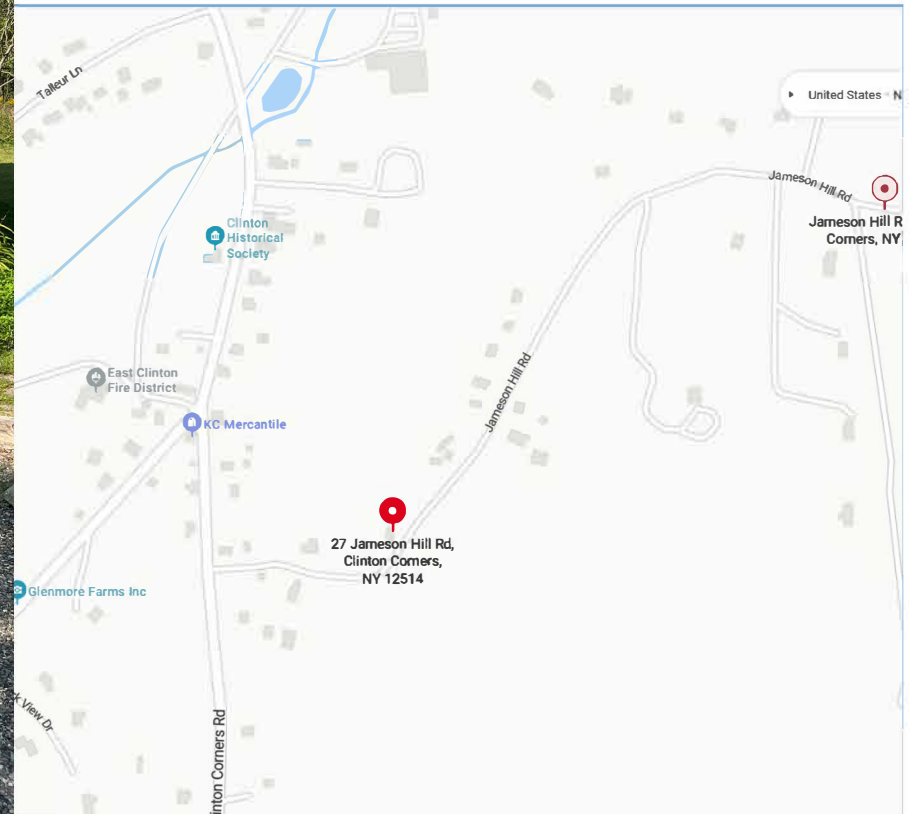



Manufacturer stock photo of proposed gazebo

24X12 ARCADIA

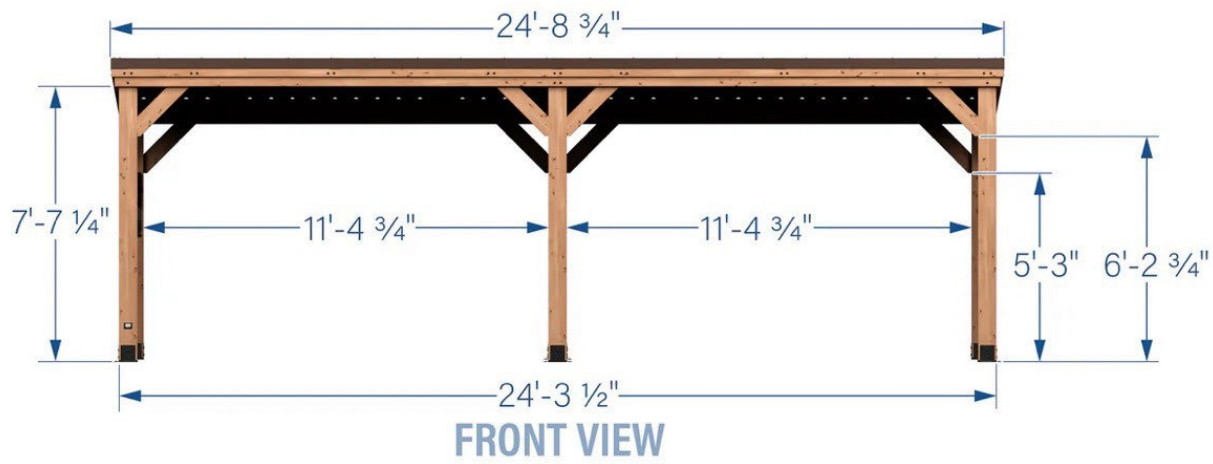
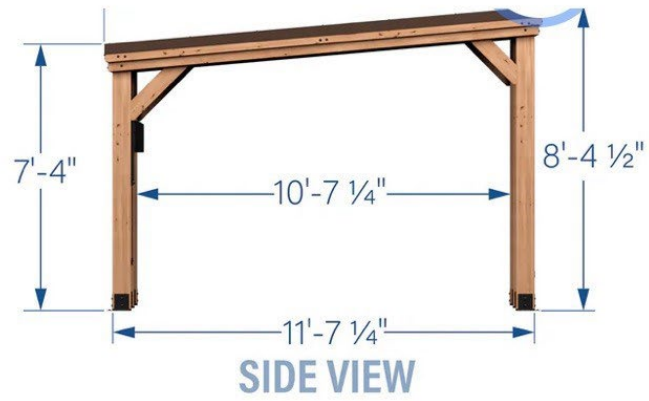

Dimensions



Photoshopped image of gazebo installed



Homeowners/Applicants property including both Parcel 623685 which contains the residence and location of the proposed gazebo and Parcel 616683, also part of the owners property and deed



View looking north



View looking south



View across the street



Gazebo site



Other structures
on Jameson Hill
with minimal
setback



Similar
structures
on Jameson
Hill Road

