

Note: all exterior lighting fixtures to be dark sky compliant

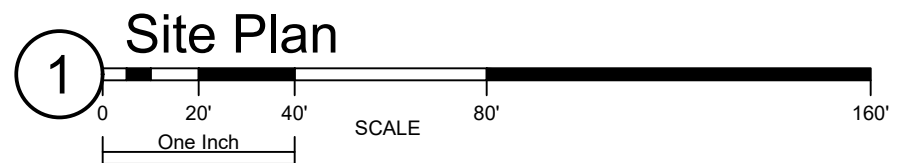
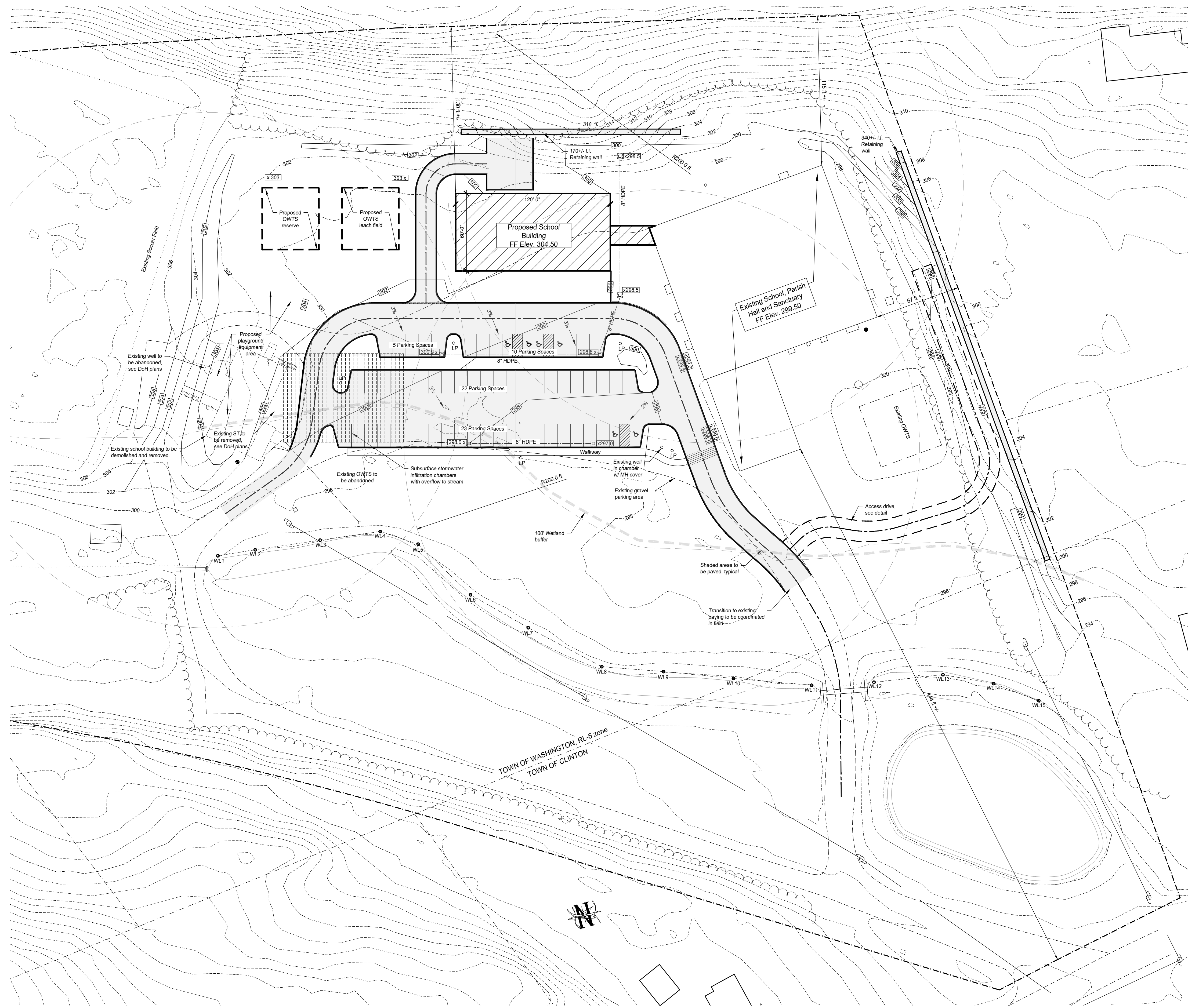
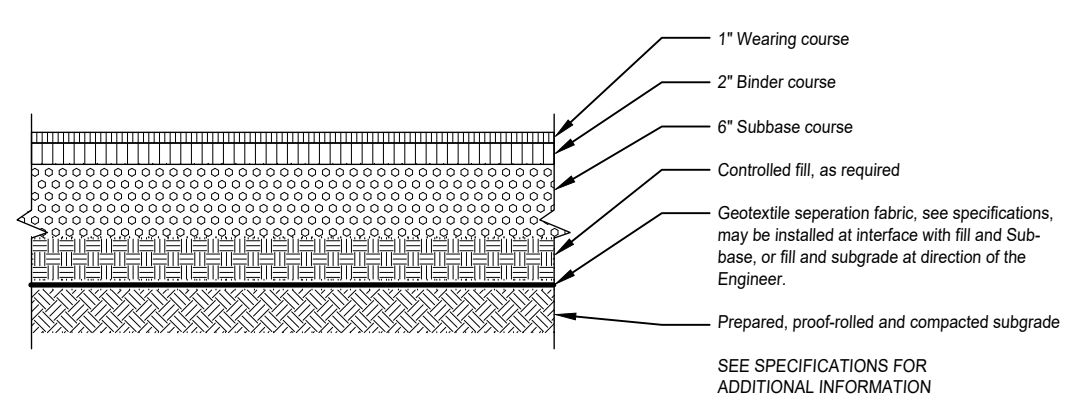
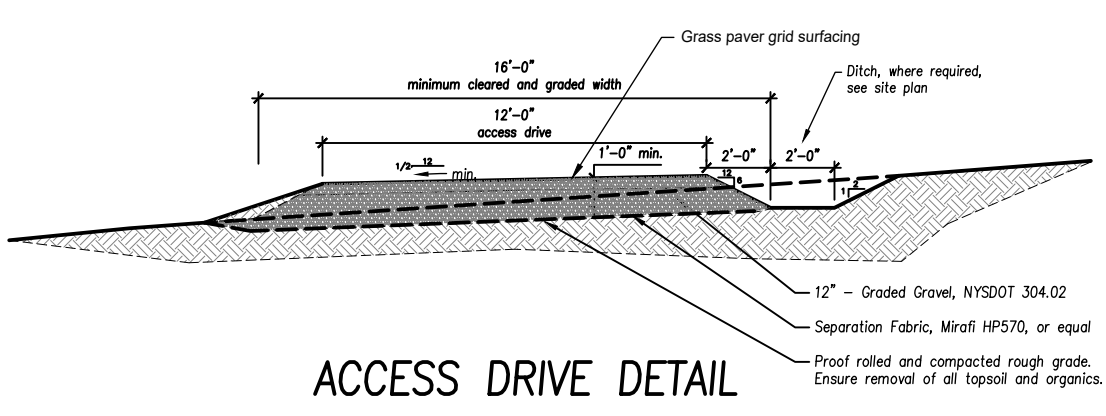

EROSION CONTROL NOTES

a. At the time of application for a Building Permit, and prior to any land clearing or site preparation work for construction of improvements on any of the lots as approved herein, an Erosion and Sediment Control Plan shall be prepared in accordance with section 335 of the Town Zoning Law shall be submitted to the Planning Board for review and approval. No Building Permit shall be issued for any improvement until the Erosion and Sediment Control Plan has been approved.

b. The discharger, owner or operator shall at all times comply with the New York State SPDES General Permit (GP-02-01) requirements. A copy of any completed Notice of Intent submitted to the New York State Department of Environmental Conservation pursuant to GP-02-01 shall be submitted to the Planning Board.

Property Notes:

Owner:
Evangelical Free Church, Inc.
PO Box 157
Clinton Corners, NY 12514

Acreage (total): 48.42 acres

Tax Parcel IDs:
T. Washington: 6566-00-648951
T. Clinton: 6566-02-587843
T. Stanford: 6567-00-703007

Town of Washington zoning:
Zone: RL-5
Use: Community Service, Religious (DCPA)
Church, Educational Institution*
(special permit, site plan)

Lot size: min. 5 acre; 300 ft. wide;
Yards:
Front: 100' req'd; 444 +/- existing;
Sides: 75' req'd; 0 +/- existing;
Rear: 75' req'd; 130 proposed;
Max. Height: 2.5 stories/ 35 ft.; proposed 42 ft.
Max. Coverage: 10%; proposed ~1.6%
Min. Frontage: 300 ft./400 ft. per §320; 58 ft +/- existing

Parking requirements:
Educational use: 1/each employee + 1/for "adult" student
20 faculty + 20 "adult" students max.;
20 + 5 = 25 spaces required;
Assembly use: 1/each four seats; non-concurrent with school
250 seats max./4 = 62.5 spaces
60 spaces provided

Approved by resolution of the Planning Board of the Town of Washington, New York on the _____ day of _____, 20____ subject to all requirements and conditions of said resolution. Any change, erasure, modification or revision of this plan as approved shall void this approval. Signed this _____ day of _____, 20____

Chair



REVISIONS		
No.	Description	Date
1-3	per Planning comments	11/21/22, 12/19/22 & 1/19/23
4	added surveyed wetland flags; revised parking & access	4/3/23

PROJECT NUMBER 569-01 November 1, 2022

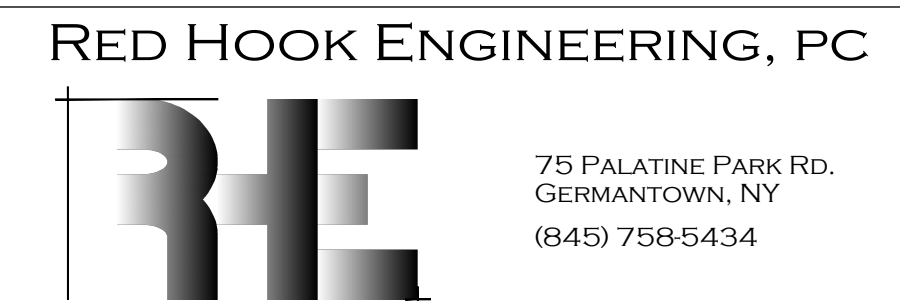

BOVEE CONSTRUCTION

**SCHOOL BUILDING FOR
EVANGELICAL FREE CHURCH, INC.**
20 SHEPHERDS WAY
TOWN OF WASHINGTON, NY

**SITE PLAN
C-102**